

Hidden Isochema IMI Series

Manometric Gas Sorption Analyzers



www.hiddenisochema.com

About Hiden Isochema

Hiden Isochema is a world leader in the design and manufacture of sorption instruments for research, development and production applications in surface chemistry and materials science.

We have been producing sorption measurement systems since 1992 when Hiden Analytical first began manufacturing the Intelligent Gravimetric Analyzer (IGA). Following a decade of continued success, Hiden Isochema was formed as a wholly-owned subsidiary of Hiden Analytical in order to further specialize in the development and manufacture of sorption-specific instrumentation.

Since then, we have expanded our product range to include unique climate control and manometric sorption systems, and we continue to strengthen our reputation for delivering high quality and versatile instrumentation while providing industry-leading levels of technical support.



Powerful Tools for Sorption Science

The **IMI** series offers a multifunctional platform for the study of physisorption, chemisorption and gas absorption by materials, from entry level manometric analyzers to advanced multistream dynamic flow systems with integrated mass spectrometry.

These versatile instruments satisfy the demands of a diverse range of applications, from surface area determination to high pressure studies, from gas storage and separation to high pressure catalysis.

The key features of the **IMI** series include:

Fully upgradable modular design

Static and dynamic operational mode options

Automatic switching between static and multistream operation

Multi-gas control providing programmable sorbate selection

Versatile instrument control from standard methods to complete user defined experiments

Adaptive analysis software including end point detection for sorption processes, reaction kinetics and sample pretreatment

Full integration of mass spectrometers from Hiden's quadrupole range enabling synchronized instrument control and data acquisition

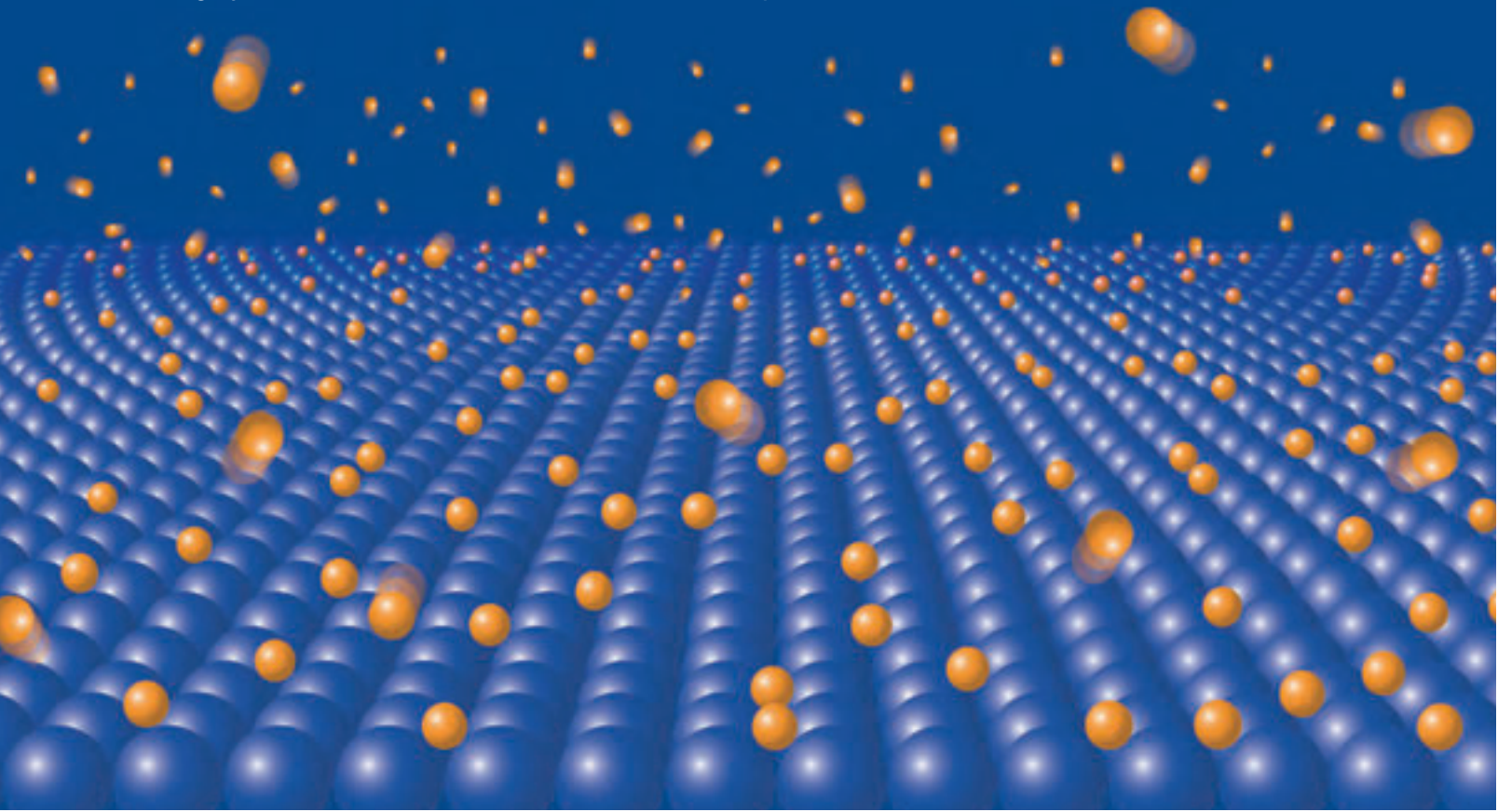

Principles of Operation

Static Mode

The manometric gas sorption measurements performed by IMI systems utilize a change in pressure within a fixed volume to determine the amount of gas sorbed or desorbed by a sample.

Upon pressurization, the number of moles of gas, n_m , in an IMI system of volume, V , is given by the real gas law,

$$n_m = \frac{pV}{ZRT} \quad (1)$$

During a sorption experiment, an aliquot of gas is delivered from a dosing volume, V_1 , to the reactor volume, V_2 , by opening a separating valve. In the absence of sorption, the instantaneous pressure drop from the initial dosing pressure, p_1 , to the final pressure, p_2 , is given by the following molar balance,

$$\frac{p_1 V_1}{ZRT} = \frac{p_2 (V_1 + V_2)}{ZRT} \quad (2)$$

A drop in pressure beyond p_2 indicates that sorption has occurred. The amount of gas sorbed, Δn_m , is then calculated from the final equilibrium pressure, p_3 ,

$$\Delta n_m = \frac{p_1 V_1}{ZRT} - \frac{p_3 (V_1 + V_2)}{ZRT} \quad (3)$$

For a high quality measurement, p_x and V_x must be known accurately and, in Eq. (3), the temperature, T , is assumed to be constant. Since the sample held inside V_2 is often at a significantly different temperature to V_1 , the temperature differential must be accounted for by modifying Eq. (3) appropriately.

A full gas sorption isotherm can be determined by sequentially dosing gas and recording the equilibrium uptake at various pressures. The reversal of the process results in the measurement of the corresponding desorption isotherm.

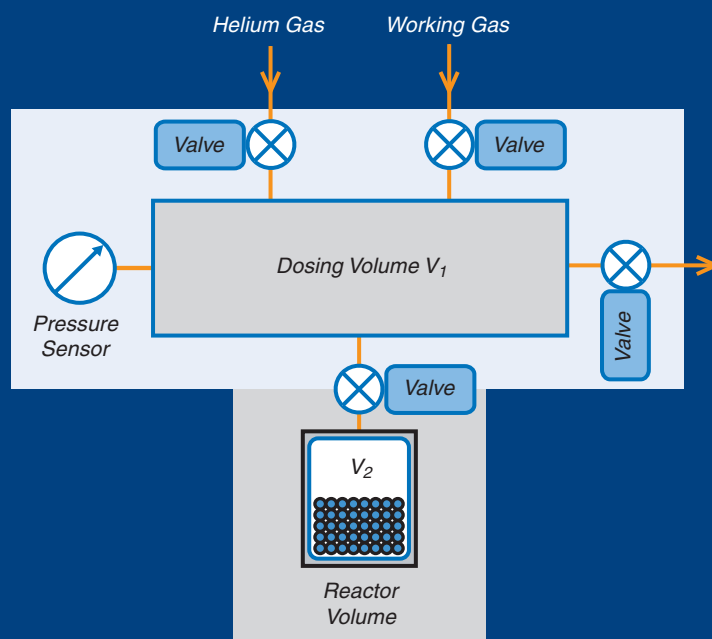

Figure 1 A schematic diagram of an IMI manometric sorption analyzer

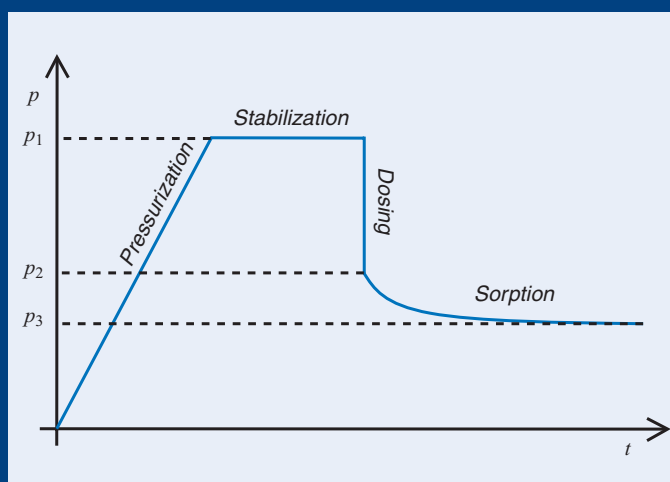

Figure 2 A schematic plot of a single dosing step, showing pressure as a function of time during a manometric sorption measurement

Dynamic Mode

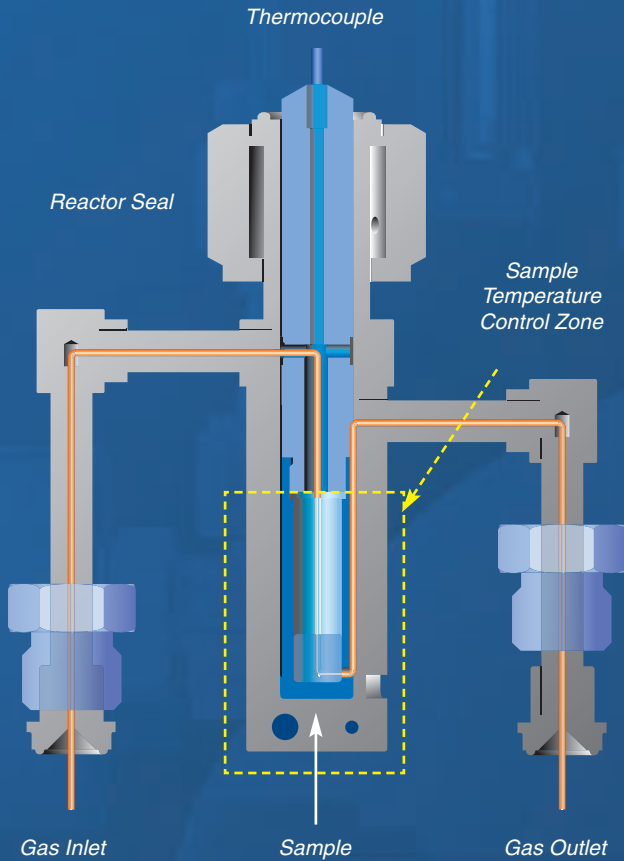

Figure 3 A layout drawing of the standard IMI reactor, indicating the reactor gas flow path for dynamic (flow) experiments

In addition to static mode operation, IMI systems equipped with Mass Flow Controllers (MFCs) can also function in dynamic (flowing) mode for the measurement of Temperature Programmed Desorption (TPD), and the performance of gas mixture and exchange experiments.

In a typical TPD experiment, a sample is loaded with gas in-situ at an elevated temperature and pressure. The sample is then cooled, before a linear thermal ramp is used to drive the desorption process, which is performed into an inert carrier gas stream. The active species can then be detected and quantified using an integrated quadrupole mass spectrometer or by observing a change in the composition of the gas flowing through an outlet MFC. The amount of desorbed gas can then be calculated by integrating the mass spectrometer, or flow composition, signal to give,

$$n_{tot} = \int_{t_0}^{t_1} n(t) dt \quad (4)$$

where n_{tot} is the total number of moles of desorbed gas, $n(t)$ is the number of moles of gas desorbed as a function of time, and t_0 and t_1 are the start and end times of the experiment.

Furthermore, the characteristic temperature of desorption can be determined from the peak positions in a TPD spectrum, while activation energies can be calculated from the shift in the peak position as a function of the applied temperature ramp rate.

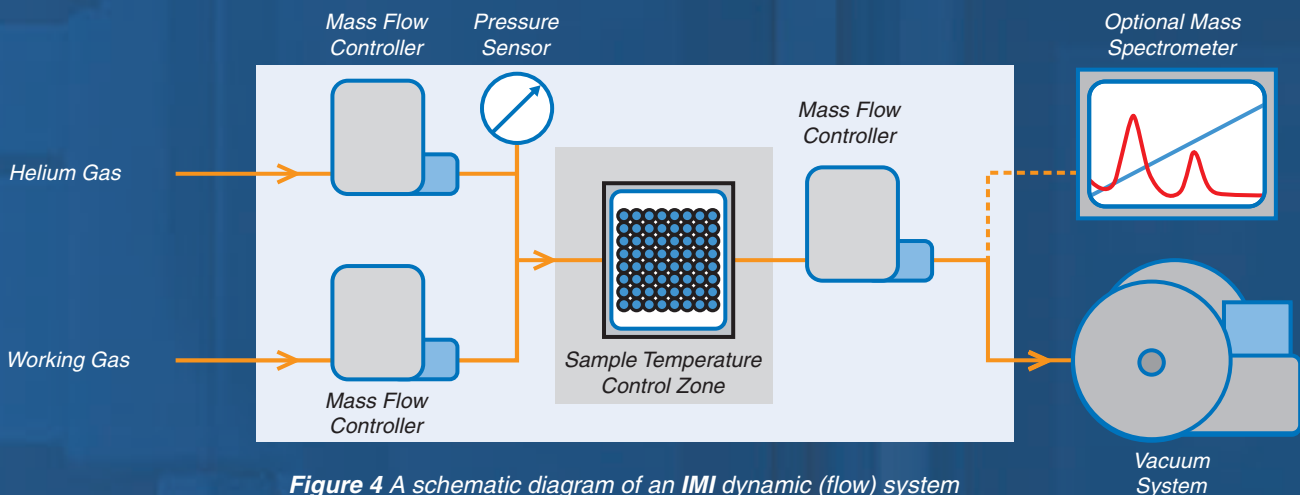
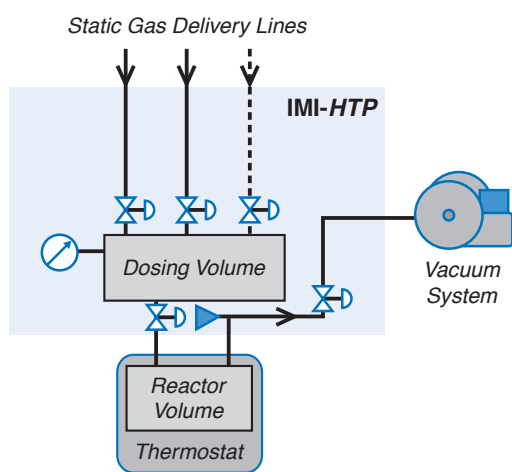

Figure 4 A schematic diagram of an IMI dynamic (flow) system

Standard IMI Systems

The IMI series consists of a number of standard instrument configurations, each of which is optimized for a specific application or research area, as shown in the diagrams below. Additionally, the modular design makes it straightforward to retrospectively upgrade each IMI system in order to satisfy your future research needs.



IMI-HTP:
For hydrogen storage studies

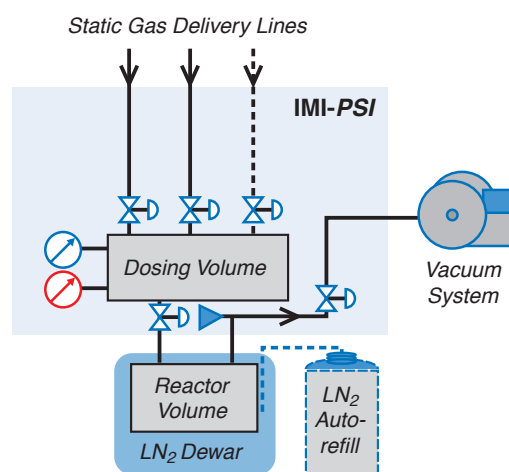

IMI-PSI:
For nanoporous materials

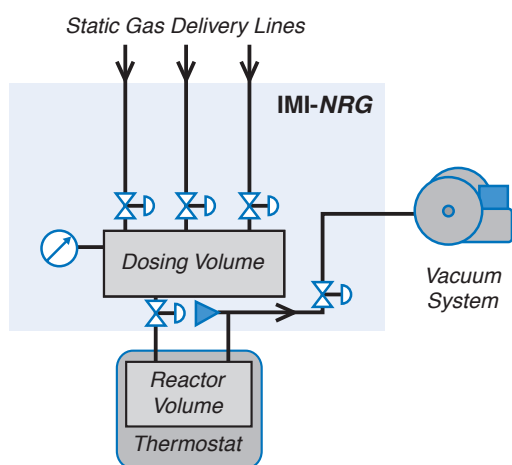

IMI-NRG:
For energy and environmental research

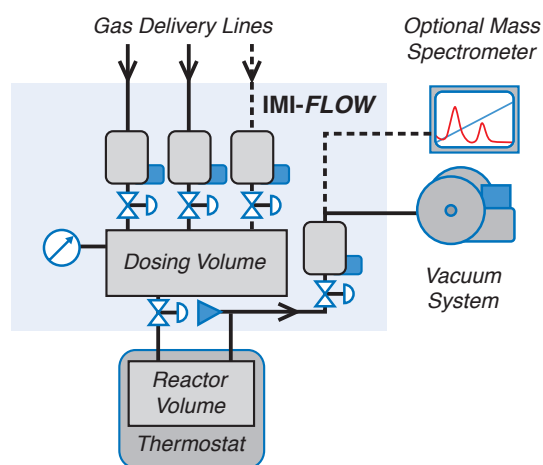

IMI-FLOW:
For dynamic flow studies

Legend

— Gas line

- - - Optional component

 Mass flow controller

 High range pressure sensor

 Low range pressure sensor

 Automatic diaphragm valve

 Bursting disc

All **IMI** systems can be used to study physisorption and chemisorption, as well as the absorption of gases by materials. Time-dependent measurements allow the observation of sorption kinetics, while equilibrium uptake determination at different temperatures can be used for the calculation of sorption enthalpies.

In addition, each model in the **IMI** range has been optimized for specific application areas:

High accuracy hydrogen storage material analyzer

- Hydrogen Storage
- Methane Storage
- Metal and Complex Hydrides
- Enthalpy of Formation/Decomposition Determination

IMI-HTP

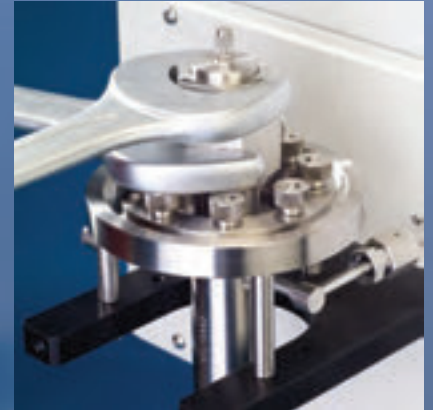

Extended pressure sorption analysis system for nanoporous media

- Porous Material Characterization
- Specific Surface Area (BET) Determination
- Confined Fluid and Capillary Condensation Analysis

IMI-PSI

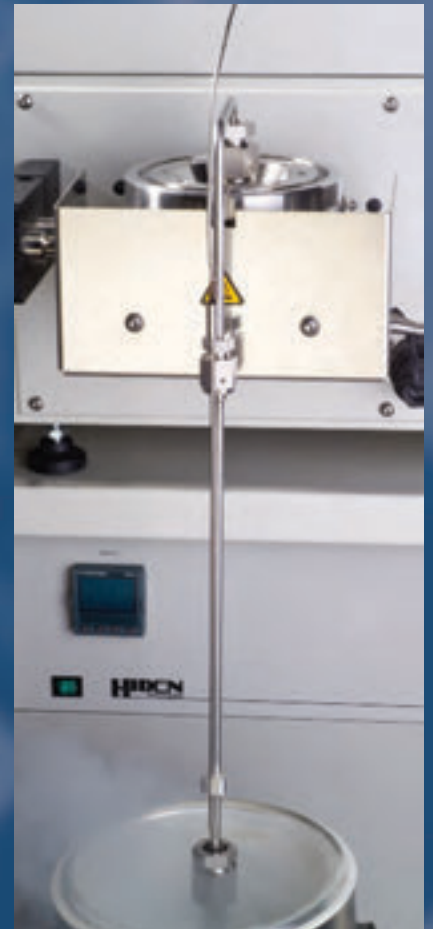

Versatile sorption analyzer for energy and environmental science

- Carbon Capture and Storage
- Shale Gas and Coal Bed Methane
- Geological CO₂ Sequestration
- Gas Solubility in Ionic Liquids
- Oxygen Storage

IMI-NRG

State-of-the-art dynamic flow and thermal desorption system

- Gas Separation and Purification
- Breakthrough Curve Determination
- High Pressure Catalysis and Catalyst Deactivation
- Isotope Exchange (SSITKA)
- Temperature Programmed Studies (TPR/TPO/TPD)

IMI-FLOW

High Accuracy Hydrogen Storage Material Analyzer



The **IMI-HTP** is designed primarily for the investigation of novel hydrogen storage materials using Sieverts' Method up to pressures of 200 bar. It offers highly automated sorption measurement procedures, as well as full control over all experimental parameters. This flexibility enables fully programmable operation throughout the entire measurement pressure range, with the sample temperature controllable from ambient up to 773 K. Optional cryocooling can extend this range down to cryogenic temperatures.

The system hardware, including the stainless steel construction, all-metal seals, and oil-free vacuum degassing capability, is specified to meet the challenging demands of high pressure hydrogen operation, while the reactor features permanent overpressure protection to satisfy the most rigorous safety requirements.

The instrument's inherent flexibility allows users to characterize the fundamental properties of hydrogen storage materials by determining PCT (Pressure-Composition-Temperature) relations, kinetic rates of absorption and desorption, and van 't Hoff plots for the calculation of sorption enthalpies. Applied experiments, such as cyclic thermal and pressure stability testing, can then be used to assess the potential of a material to suit real-world applications.

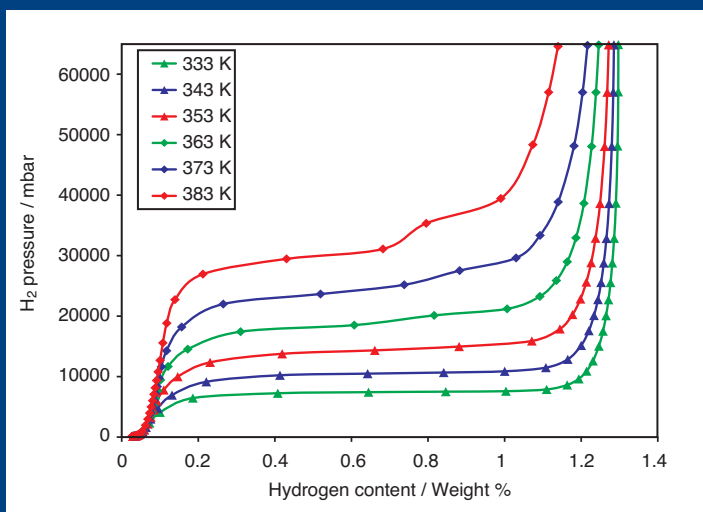

Figure 5 Desorption isotherms for the $\text{LaNi}_5\text{-H}$ system, measured at six temperatures using an **IMI-HTP** hydrogen storage material analyzer

Model	IMI-HTP
Key Feature	Sub- μg Hydrogen Sorption Resolution
Max. Pressure	100 / 200 bar
Applications	PCT Measurements Energy Gas Storage Metal Hydrides Sorption Enthalpy Determination

Extended Pressure Sorption Analysis System for Nanoporous Media

The **IMI-PSI** is specifically designed for the investigation of gas sorption by nanoporous materials, at both low (cryogenic) and elevated temperatures. It allows the adsorption behaviour of porous solids to be characterized at the temperatures and pressures relevant for gas storage, gas separation and other sorption-based technologies. The system can also be used to determine the surface area and other pore structure characteristics of nanoporous materials. Operation is available up to 200 bar, and an additional high accuracy 1 bar pressure range is also included as standard. This provides optimum resolution at the sub-ambient pressure conditions required for the study of gas-solid surface interactions.

Supplied with an immersion reactor and high performance Dewar, the **IMI-PSI** provides optimal thermal stability at cryogenic temperatures, which is a crucial factor for high accuracy measurement. The IMIwin software features a range of data fitting functions, including BET analysis for the determination of the specific surface area.

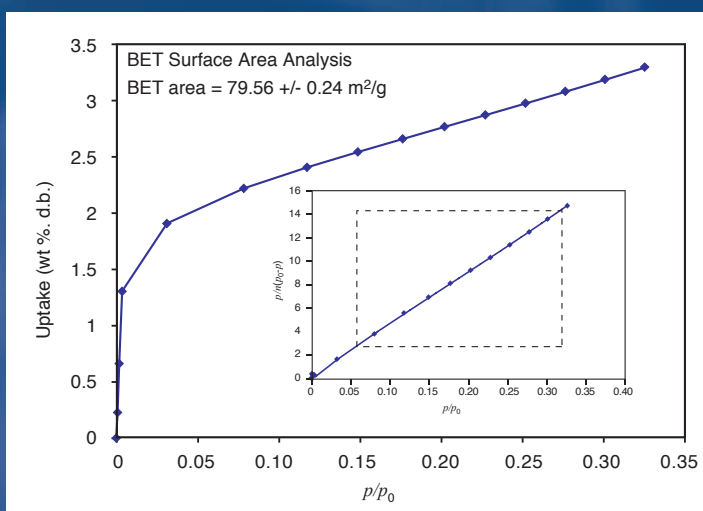

Figure 6 BET analysis of the specific surface area of the BAM-PM-104 Standard Reference Material measured on an **IMI-PSI**, using nitrogen adsorption at 77 K. The inset shows the BET plot, with the fit performed using the relative pressure range, $p/p_0 = 0.08$ to 0.3

Model	IMI-PSI
Key Feature	77 K Liquid Nitrogen Immersion Reactor (1 cm ³)
Max. Pressure	100 / 200 bar
Applications	Porous Materials BET Surface Area Isotherm Hysteresis

Versatile Sorption Analyzer for Energy and Environmental Science



The **IMI-NRG** provides a fully integrated system for energy and environmental science research. It has been developed specifically for the characterization of materials for gas separation, capture and storage applications, which have many potential uses in this field, including the storage of energy gases, and CO₂ capture and sequestration.

High pressure operation to 200 bar is offered as standard with a high accuracy pressure sensor for the full measurement range.

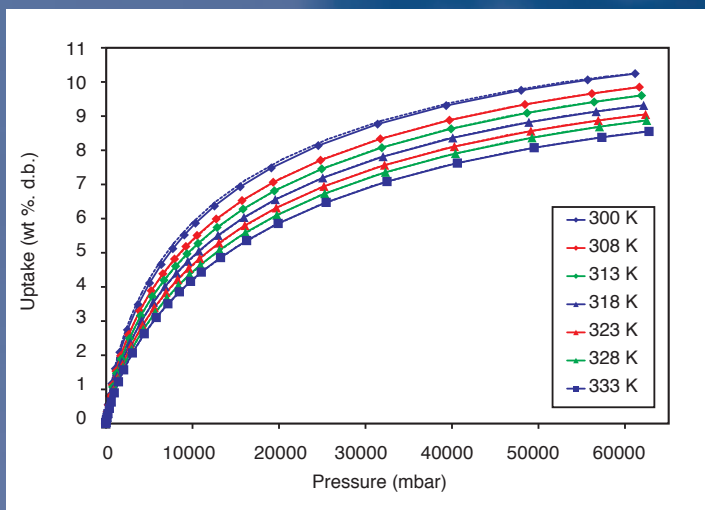

Figure 7 Reversible methane sorption isotherms measured on a commercial activated carbon (Filtrisorb F-400) in an **IMI-NRG** with a large sample reactor between room temperature and 333 K. Adsorption is shown with a solid line while desorption is dashed

Model	IMI-NRG
Max. Pressure	200 bar
Applications	Carbon Capture and Storage Geological CO ₂ /CH ₄ Gas Solubility in Ionic Liquids Oxygen Storage

State-of-the-Art Dynamic Flow and Thermal Desorption Analyzer

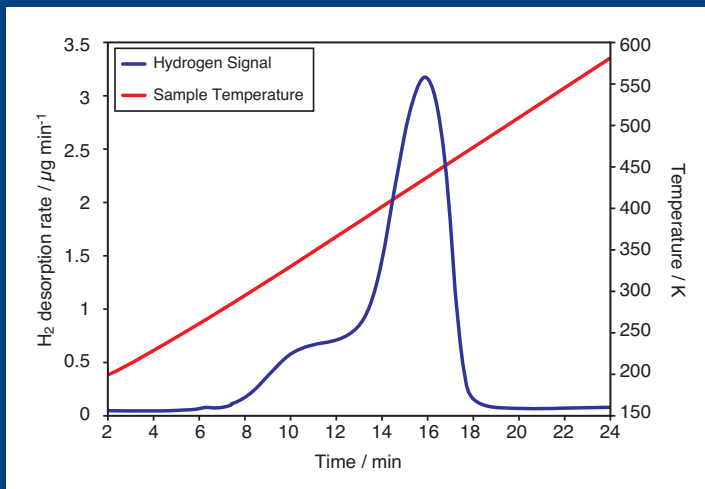

Figure 8 A thermal desorption (TPD) spectrum showing the amount of hydrogen released from a 3 mg Pd sample hydrogenated in-situ at an elevated temperature and pressure in an IMI-FLOW. The hydrogen signal was determined using an optional dynamic sampling mass spectrometer

The **IMI-FLOW** combines the static mode measurement capabilities of the full IMI range with unique dynamic (flowing) mode operation, allowing the performance of Temperature Programmed Desorption (TPD) as well as mixed gas experiments. High performance MFCs are used to regulate the flow of gas, while the integrated sample reactor heating system allows the precise control of the applied linear thermal ramp rates. Optional liquid nitrogen cryocooling allows the performance of TPD from cryogenic temperatures.

In the **IMI-FLOW**, thermal desorption is performed into an inert carrier gas stream and detected using a downstream MFC or an optional integrated quadrupole mass spectrometer. The design of the instrument incorporates a low volume gas pathway for both a rapid response and maximum sensitivity. The addition of a dynamic sampling quadrupole mass spectrometer for evolved gas analysis, combined with multiple flow streams, also allows the performance of gas mixture and exchange experiments.

The versatile and integrated nature of the **IMI-FLOW**, which allows direct control of a close-coupled mass spectrometer from the IMIwin software suite, makes it a unique and sophisticated analysis system.

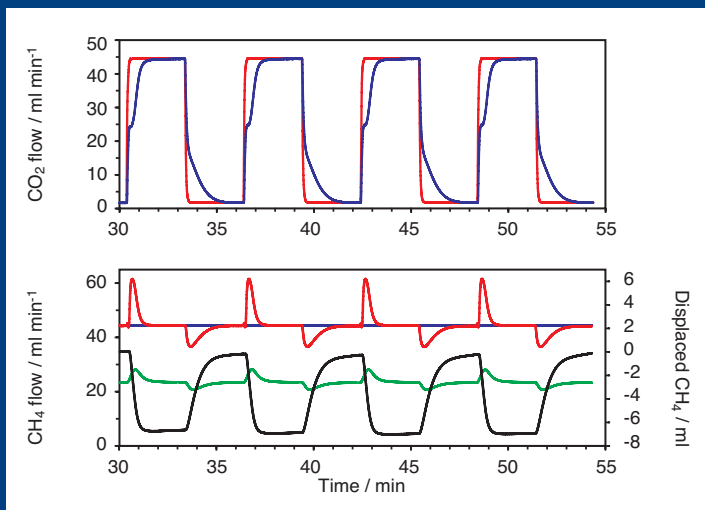

Figure 9 Dynamic flow experiment designed to determine the nature of selective adsorption of CO₂ over CH₄. The inlet and outlet CO₂ flows are shown above, while CH₄ flow/displacement and temperature are shown below. See Hiden Isochema Application Note 129 for more information

Model	IMI-FLOW
Key Feature	Dynamic Gas Flow Control & Integrated Mass Spectrometer Compatibility
Max. Pressure	100 / 200 bar
Applications	Gas Separation Breakthrough Curves TPR/TPO/TPD Catalysis / SSITKA

Reactor Options



Large Capacity Sample Reactor

This custom-designed reactor offers additional sample capacity of up to 10 cm³, and therefore provides IMI systems with the flexibility to investigate either low density samples, upscaled production methods or materials exhibiting only modest uptakes. Volume displacers are also available to accommodate smaller samples. The large capacity sample reactor is fully compatible with the enhanced anti-condensation protection and liquid nitrogen cryocooling options, and comes equipped with a 773 K integral heater as standard.

Removable Reactor

The removable reactor allows IMI systems to be used in conjunction with existing laboratory inert environment handling facilities. The reactor is designed to be easily detached and transferred into a glovebox, in which air or moisture sensitive samples can be safely loaded or unloaded. The removable reactor comes complete with an integral heater for sample degassing and temperature control.



Cryocooling System

Liquid nitrogen cryocooling provides accurate control at low temperatures for the standard, large capacity and removable reactors. The cryocooling system feeds liquid nitrogen to the reactor while the integrated heater allows the temperature to be regulated and controlled precisely throughout the full operating temperature range. The circulation of the liquid nitrogen is driven by a dedicated pumping unit, which is conveniently mounted in the standard IMI mobile cart.

System Accessories



Detachable Sample Loading Glovebox

The detachable glovebox allows air or moisture sensitive samples to be loaded and unloaded from an IMI system, under an inert atmosphere, in laboratories without dedicated glovebox facilities. The glovebox is sealed onto the reactor flange and purged with dry inert gas from an external supply. It is mounted on a dedicated trolley and supplied complete with resealable storage and transfer vessels and a spare sample holder to enable rapid interchange.

Expansion Volumes

For further flexibility, IMI systems may be fitted with a number of expansion vessels to enlarge the dosing volume and hence provide different aliquot delivery capabilities. This provides greater flexibility in the development of experimental methodology and allows the anticipated pressure change due to sorption to be varied according to specific research needs. Up to four additional vessels can be included, providing up to 16 different dosing volume permutations, each of which may be automatically selected through the IMIwin software.



Customer Support

Hidden Isochema believes that scientific and technical support is as important as your custom, and counts customer satisfaction as the most important measure of excellence. User training and continued application-focused support are vital services that we consider to be integral to our products.

Our field engineers offer a wealth of technical experience, while our PhD-qualified applications team offer both a practical and scientific perspective in order to provide you with the very best in product support and customer service. This knowledge base, combined with our proactive approach, makes Hidden Isochema the respected leader in the industry.



As part of this commitment, we offer:

- Comprehensive 12 month warranties on all instruments
- On-site installation, commissioning and training
- Advanced or bespoke user training courses on demand
- Lifetime technical support and free software upgrades for academic users
- A 24 hour response time to scientific and technical support enquiries

Hidden Isochema Quality and Safety

To ensure the highest standards of safety, product and service provision, Hidden Isochema is fully compliant with a number of key safety and quality codes:

- ISO 9001:2008 (BSI) Quality Standard
- European Union Pressure Equipment Directive PED 97/23/EC
- European Union Electromagnetic Compatibility and Electronic Safety Directives 87/336/EEC and 73/23/EC
- DQ/IQ/OQ procedures (full certification supplied upon request)

Need More Information?

Contact us now: info@hidenisochema.com
or via www.hidenisochema.com

Technical Specifications:

System Construction	Wetted components: Manifolds Valve diaphragms Pressure transducer diaphragms	All metal Stainless steel (316L) Elgiloy Hastelloy C276
Typical Species	Energy gases: Atmospheric/environmental gases: Noble gases: Supercritical fluids:	Hydrogen, deuterium, methane, ethane, ethene Nitrogen, oxygen, carbon dioxide, carbon monoxide Helium, neon, argon, krypton, xenon Carbon dioxide, ethane, xenon
Sample Reactors	Maximum bulk sample volume: Construction material: Internal sample holder: Reactor seal: Overpressure protection:	~1 cm ³ (Standard, Immersion, Removable Reactors) ~10 cm ³ (Large Capacity Reactor) Stainless steel (316L) Gold-plated copper (stainless steel available on request) Cajon VCR Permanent (electron beam welded nickel foil burst disc)
Temperature	Measurement range: Temperature sensors: Accuracy: Typical regulation accuracy: Cabinet regulation accuracy:	77 – 773 K Platinum Resistance Thermometer (Pt100) or Type-K thermocouple ± 1 K (Type-K) or ± 0.1 K (Pt100) ± 0.1 K ± 0.1 K
Pressure	Maximum operating pressure: Typical accuracy: Transducer ranges: Base vacuum: Compressibility correction accuracy: Sorption measurement resolution:	100 bar (optionally 200 bar) ± 0.05 % of range 2, 10, 100 mbar 1, 10, 100, 200 bar < 10 ⁻⁶ mbar with turbomolecular vacuum pump 0.1 % (NIST fluid properties database) < 1 μmol
Dynamic Gas Flow Control (IMI-FLOW)	Control method: Number of gas inlets: Typical switching time: Maximum flow rate:	Thermal mass flow control Up to 8 1 – 3 seconds for specified composition 1000 ml min ⁻¹
Mass Spectrometer (IMI-FLOW)	Coupling method: Atomic mass range: Detector:	Heated stainless steel or Quartz Inert Capillary (QIC) inlet 1 – 200 a.m.u. (standard) 1 – 50 a.m.u (optimized for light gas detection) Dual Faraday/electron multiplier

It is Hiden Isochema's policy to continually improve product performance and therefore specifications are subject to change.

Hiden Isochema

Advancing Sorption Analysis



Hiden Isochema Ltd

Tel: +44 (0) 1925 244 678
 Fax: +44 (0) 1925 244 664
 Email: info@hidenisochema.com
 Web: www.hidenisochema.com

